

LILIA

Silla LILIA
Chair LILIA
Chaise LILIA

19540 EAN Code: 8435178348531
19541 EAN Code: 8435178348548
19542 EAN Code: 8435178348555

Instrucciones de Montaje
Assembly Instructions
Notice de Montage
Istruzioni di Montaggio
Instruções de Montagem
Upute za Montazu
Montaj Talimati

Version 10/10/2025

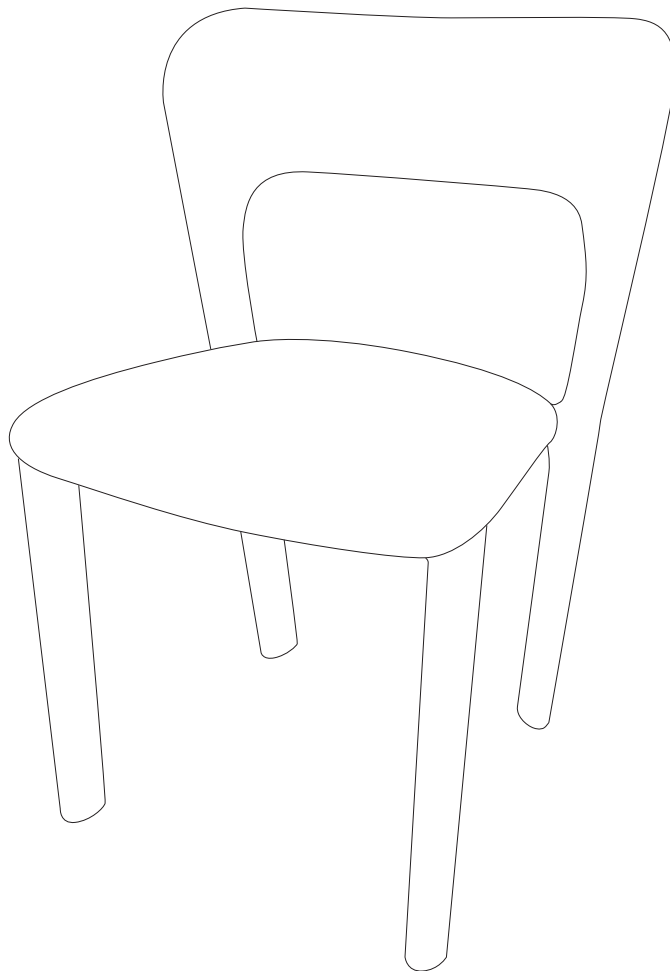

MARCKERIC S.L.
c/ Enlace Verola S/N
46430 Sollana - Valencia (SPAIN)
ventas@marckeric.com

mome

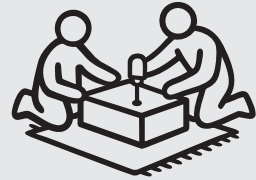

ES: → Este mueble es para uso doméstico

→ No desplace un mueble que esté cargado.

→ Si hubiera piezas de la silla dañadas o gastadas, deje de usar la silla y sustitúyala.

→ ¡ADVERTENCIA! No utilice este asiento para personas con discapacidad física y que necesiten una posición sentada continuada y frecuente. Este producto deberá utilizarse en un entorno de ocio o relajación. Este producto no cumple con las normas en vigor para material médico.

→ En las sillas con elevación por gas, el cambio o la reparación de la elevación por gas deberán ser efectuados por una persona cualificada.

→ En las sillas con sistema de inclinación, la inclinación por encima de 120° no es considerada un uso normal del producto. Tenga en cuenta el riesgo de vuelco hacia atrás.

→ En las sillas, sillones y sofás con brazos, el brazo no es ni una mesa ni un asiento: por tanto, no se sienta sobre el mismo.

EN: → This furniture is for domestic use.

→ Do not move furniture that is loaded.

→ If parts of the chair are damaged or worn, discontinue use and replace it.

→ WARNING! Do not use this seat for people suffering of a physical handicap, and needing a seated continue and frequent position. This product shall be used in a frame of leisure or relaxation. This product does not comply with the norms in force for medical material.

→ In chairs with gas lift, the replacement or repair of the gas lift must be carried out by a qualified person.

→ In chairs with a tilting system, reclining beyond 120° is not considered normal use of the product. Please be aware of the risk of tipping backwards.

→ In chairs, armchairs, and sofas with armrests, the armrest is neither a table nor a seat: therefore, do not sit on it.

FR: → Ce meuble est à usage domestique.

→ Ne pas déplacer un mobilier chargé.

→ Si des pièces du fauteuil sont endommagées ou usées, ne plus l'utiliser et le remplacer.

→ ATTENTION! Ne pas utiliser ce siège pour des personnes souffrant d'un handicap physique et nécessitant la position assise continue et fréquente. Ce siège ne doit être utilisé que dans le cadre du loisir ou de la relaxation. Ce siège ne répond pas aux normes en vigueur du matériel médical.

→ Sur les chaises avec vérin à gaz, le remplacement ou la réparation du vérin à gaz doit être effectué par une personne qualifiée.

→ Sur les chaises avec système d'inclinaison, une inclinaison au-delà de 120° n'est pas considérée comme une utilisation normale du produit. Veuillez noter le risque de basculement vers l'arrière.

→ Sur les chaises, fauteuils et canapés avec accoudoirs, l'accoudoir n'est ni une table ni un siège : ne vous asseyez donc pas dessus.



IT: → Questo mobile è destinato all'uso domestico.

→ Non spostare un mobile carico.

→ Se dei componenti della poltrona sono danneggiati o usurati, non utilizzarla più e sostituirla.

→ **ATTENZIONE!** Questo prodotto non deve essere usata da persone con disabilità fisica e che devono rimanere sedute in modo continuo e frequente. Questo prodotto deve essere utilizzato esclusivamente per il relax e il tempo libero. Questo prodotto non soddisfa i requisiti in vigore per i materiali medici.

→ Nelle sedie con alzata a gas, la sostituzione o riparazione del meccanismo a gas deve essere effettuata da una persona qualificata.

→ Nelle sedie con sistema di inclinazione, un'inclinazione superiore a 120° non è considerata un uso normale del prodotto. Prestare attenzione al rischio di ribaltamento all'indietro.

→ Nelle sedie, poltrone e divani con braccioli, il bracciolo non è né un tavolo né un sedile: quindi non sedersi sopra.

PT: → Este móvel é para uso doméstico.

→ Não mova o móvel quando estiver carregado.

→ Se partes da cadeira ficarem danificadas ou gastas, pare de a usar e substitua-a.

→ **AVISO!** Este assento não deverá ser usado por pessoas que sofram de deficiências físicas e que precisem de uma posição sentada contínua e frequente. Este produto deverá ser usado para lazer e relaxamento. Este produto não se encontra em conformidade com as normas em vigor para material médico.

→ Em cadeiras com elevação a gás, a substituição ou reparação do mecanismo a gás deve ser feita por uma pessoa qualificada.

→ Em cadeiras com sistema de inclinação, inclinar além de 120° não é considerado um uso normal do produto. Tenha atenção ao risco de tombamento para trás.

→ Em cadeiras, poltronas e sofás com braços, o braço não é uma mesa nem um assento: portanto, não se sente sobre ele.

DE: → Dieses Möbel ist für den Hausgebrauch bestimmt.

→ Bewegen Sie keine Möbelstücke, die beladen sind.

→ Verwenden Sie den Sessel nicht mehr und ersetzen Sie ihn, falls Teile des Sessels beschädigt oder abgenutzt sind.

→ **ACHTUNG!** Diesen Sitz nicht für Personen mit körperlichen Behinderungen verwenden, die kontinuierlich oder häufig sitzen müssen. Dieser Sitz darf nur zur Erholung oder Entspannung verwendet werden. Dieser Sitz entspricht nicht den geltenden Normen für medizinische Geräte.

→ Bei Stühlen mit Gasfeder muss der Austausch oder die Reparatur der Gasfeder von einer qualifizierten Person durchgeführt werden.

→ Bei Stühlen mit Neigungssystem gilt eine Neigung über 120° nicht als bestimmungsgemäßer Gebrauch des Produkts. Bitte beachten Sie die Kippgefahr nach hinten.

→ Bei Stühlen, Sesseln und Sofas mit Armlehnen gilt: Die Armlehne ist weder ein Tisch noch ein Sitzplatz – setzen Sie sich daher nicht darauf.

Medidas-Measures-Mesures



ES: Peso máximo recomendado.
 EN: Maximum weight recommended.
 FR: Poids maximum recommandé.

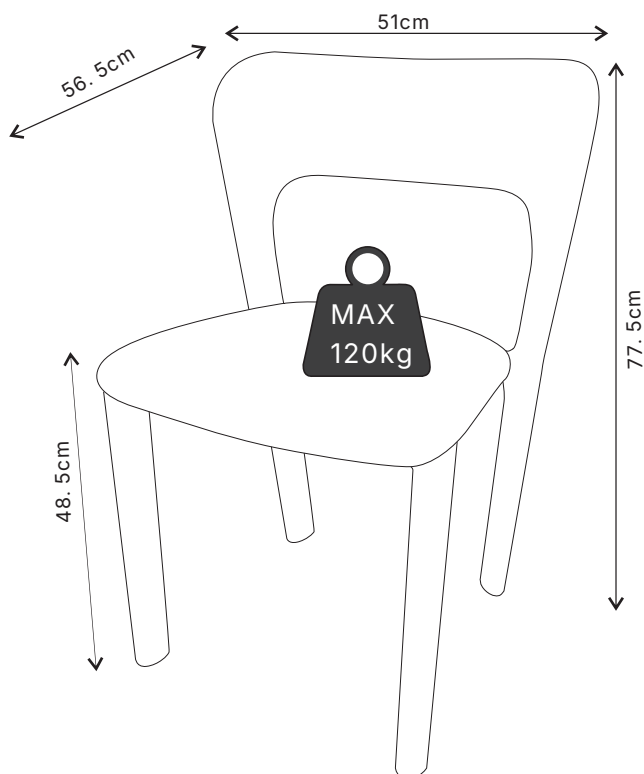

Caja-Box-Colis 1/

Piece 02 x 1 un.

Hoja de montaje
 Assembly sheet
 Notice de montage



2PC / 1CTN

Caja Box Colis	Tamaño de la caja Box dimensions Dimensions colis	Peso neto Net weight Podis net	Peso bruto Gross weight Podis brut
2/1	650x530x890 mm	5,7 kg	15 ,2 kg



ES: Composición del producto
 tela, metal y espuma.

EN: Product Composition
 fabric, metal and foam

FR: Composition du produit
 tissu, métal et mousse

IT: Composizione del prodotto
 tessuto, metallo e schiuma

PT: Composição do produto
 tecido, metal e espuma

DE: Produktzusammensetzung
 Stoff, Metall und Schaum



ES: En caso de reclamación, por favor, facilite la información que aparece en la etiqueta ID.

EN: If you may have whatever complaint, please, let us know the information written on the ID label

FR: En cas de réclamation, merci de transmettre les informations contenues sur l'étiquette fixée sur le produit.

ID Label

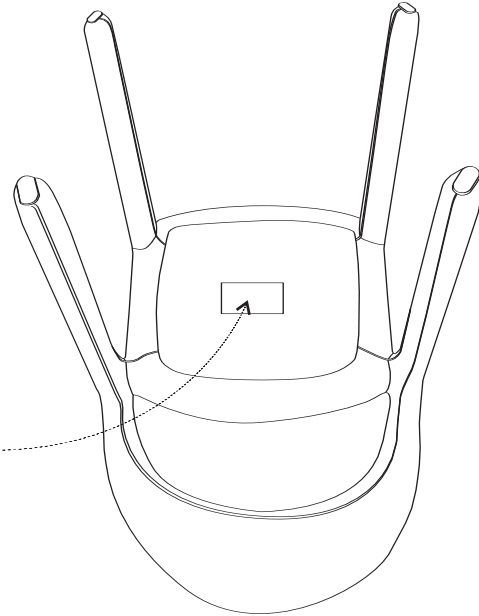

ES: Tras sacar las sillas de la caja, si es necesario, permita un tiempo para que la tapicería recupere su forma original. Si persiste alguna arruga en la curva del respaldo, alise con la mano.

EN: After taking the chairs out of the box, if necessary, allow some time for the upholstery to regain its original shape. If any wrinkles remain on the curve of the backrest, smooth them out by hand.

FR: Après avoir sorti les chaises de la boîte, laissez, si nécessaire, un certain temps au revêtement pour retrouver sa forme d'origine. Si des plis persistent sur la courbe du dossier, lissez-les à la main.

IT: Dopo aver tolto le sedie dalla scatola, se necessario, lasciare un po' di tempo affinché il rivestimento riprenda la sua forma originale. Se rimane qualche piega sulla curva dello schienale, lisciarla con la mano.

PT: Depois de retirar as cadeiras da caixa, se necessário, aguarde algum tempo para que o estofamento recupere a sua forma original. Se permanecer alguma ruga na curvatura do encosto, alise-a com a mão.

DE: Nachdem Sie die Stühle aus der Verpackung genommen haben, lassen Sie gegebenenfalls etwas Zeit, damit der Bezug seine ursprüngliche Form wieder annimmt. Wenn sich auf der Rundung der Rückenlehne noch Falten zeigen, glätten Sie diese mit der Hand.



Consejos de mantenimiento y limpieza

- Nunca fuerce las uniones.
- Conserve el manual de montaje; si falta alguna pieza, es la forma más fácil de contactar con la tienda.
- No utilice productos abrasivos, lana de acero ni disolventes.
- No moje el producto.
- Quite cuidadosamente el polvo.
- Utilice un paño ligeramente humedecido.

Instrucciones de mantenimiento
Paño suave ligeramente húmedo
Agua con jabón
Agua con detergente
Esjonja anti-rayaduras
Mantenimiento específico del fabricante

⚠ Advertencias ⚠
Antes de cualquier mantenimiento, limpie el polvo con cuidado
Cualquier mancha debe limpiarse rápidamente
No utilice productos abrasivos (polvo, lana de acero)
No utilice disolventes
No mojar
No limpiar con hidrolimpiadora (productos de exterior)

Información específica
Consulte la información adicional adjunta al producto.

Materiales												
Madera maciza aceiteada	Madera encerada	Madera barnizada o teñida	Panel de madera con papel decorativo	Paneles recubiertos de melamina	Superficie lacada	Piedras	Cuero	Metal	Plástico	Textil	Textil revestido (PU, PVC)	Producto con partes eléctricas
<input type="checkbox"/>	<input type="checkbox"/>	<input type="checkbox"/>	<input type="checkbox"/>	<input type="checkbox"/>	<input type="checkbox"/>	<input type="checkbox"/>	<input type="checkbox"/>	<input type="checkbox"/>	<input type="checkbox"/>	<input type="checkbox"/>	<input type="checkbox"/>	<input type="checkbox"/>
<input type="checkbox"/>	<input type="checkbox"/>	<input type="checkbox"/>	<input type="checkbox"/>	<input type="checkbox"/>	<input type="checkbox"/>	<input type="checkbox"/>	<input type="checkbox"/>	<input type="checkbox"/>	<input type="checkbox"/>	<input type="checkbox"/>	<input type="checkbox"/>	<input type="checkbox"/>
<input type="checkbox"/>	<input type="checkbox"/>	<input type="checkbox"/>	<input type="checkbox"/>	<input type="checkbox"/>	<input type="checkbox"/>	<input type="checkbox"/>	<input type="checkbox"/>	<input type="checkbox"/>	<input type="checkbox"/>	<input type="checkbox"/>	<input type="checkbox"/>	<input type="checkbox"/>
<input type="checkbox"/>	<input type="checkbox"/>	<input type="checkbox"/>	<input type="checkbox"/>	<input type="checkbox"/>	<input type="checkbox"/>	<input type="checkbox"/>	<input type="checkbox"/>	<input type="checkbox"/>	<input type="checkbox"/>	<input type="checkbox"/>	<input type="checkbox"/>	<input type="checkbox"/>
<input type="checkbox"/>	<input type="checkbox"/>	<input type="checkbox"/>	<input type="checkbox"/>	<input type="checkbox"/>	<input type="checkbox"/>	<input type="checkbox"/>	<input type="checkbox"/>	<input type="checkbox"/>	<input type="checkbox"/>	<input type="checkbox"/>	<input type="checkbox"/>	<input type="checkbox"/>

<input type="checkbox"/>	<input type="checkbox"/>	<input type="checkbox"/>	<input type="checkbox"/>	<input type="checkbox"/>	<input type="checkbox"/>	<input type="checkbox"/>	<input type="checkbox"/>	<input type="checkbox"/>	<input type="checkbox"/>	<input type="checkbox"/>	<input type="checkbox"/>	<input type="checkbox"/>
<input type="checkbox"/>	<input type="checkbox"/>	<input type="checkbox"/>	<input type="checkbox"/>	<input type="checkbox"/>	<input type="checkbox"/>	<input type="checkbox"/>	<input type="checkbox"/>	<input type="checkbox"/>	<input type="checkbox"/>	<input type="checkbox"/>	<input type="checkbox"/>	<input type="checkbox"/>
<input type="checkbox"/>	<input type="checkbox"/>	<input type="checkbox"/>	<input type="checkbox"/>	<input type="checkbox"/>	<input type="checkbox"/>	<input type="checkbox"/>	<input type="checkbox"/>	<input type="checkbox"/>	<input type="checkbox"/>	<input type="checkbox"/>	<input type="checkbox"/>	<input type="checkbox"/>
<input type="checkbox"/>	<input type="checkbox"/>	<input type="checkbox"/>	<input type="checkbox"/>	<input type="checkbox"/>	<input type="checkbox"/>	<input type="checkbox"/>	<input type="checkbox"/>	<input type="checkbox"/>	<input type="checkbox"/>	<input type="checkbox"/>	<input type="checkbox"/>	<input type="checkbox"/>
<input type="checkbox"/>	<input type="checkbox"/>	<input type="checkbox"/>	<input type="checkbox"/>	<input type="checkbox"/>	<input type="checkbox"/>	<input type="checkbox"/>	<input type="checkbox"/>	<input type="checkbox"/>	<input type="checkbox"/>	<input type="checkbox"/>	<input type="checkbox"/>	<input type="checkbox"/>
<input type="checkbox"/>	<input type="checkbox"/>	<input type="checkbox"/>	<input type="checkbox"/>	<input type="checkbox"/>	<input type="checkbox"/>	<input type="checkbox"/>	<input type="checkbox"/>	<input type="checkbox"/>	<input type="checkbox"/>	<input type="checkbox"/>	<input type="checkbox"/>	<input type="checkbox"/>

<input type="checkbox"/>	<input type="checkbox"/>	<input type="checkbox"/>	<input type="checkbox"/>	<input type="checkbox"/>	<input type="checkbox"/>	<input type="checkbox"/>	<input type="checkbox"/>	<input type="checkbox"/>	<input type="checkbox"/>	<input type="checkbox"/>	<input type="checkbox"/>	<input type="checkbox"/>
--------------------------	--------------------------	--------------------------	--------------------------	--------------------------	--------------------------	--------------------------	--------------------------	--------------------------	--------------------------	--------------------------	--------------------------	--------------------------



Maintenance and cleaning advices

- Never force the connections.
- Keep the assembly manual; if a part is missing, it is the easiest way to contact the store.
- Do not use abrasive powders, steel wool or solvents.
- Do not wet.
- Carefully remove dust.
- Use a slightly damp cloth.

Maintenance instructions	
Slightly damp soft cloth	<input type="checkbox"/>
Soapy water	<input type="checkbox"/>
Water with detergent	<input type="checkbox"/>
Anti-scratch scouring sponge	<input type="checkbox"/>
Manufacturer specific maintenance	<input type="checkbox"/>

⚠ Warning ⚠	
Before any maintenance, clean the dust carefully	<input type="checkbox"/>
Any stain should be cleaned quickly	<input type="checkbox"/>
Never use an abrasive product (powder, steel wool)	<input type="checkbox"/>
Never use solvent	<input type="checkbox"/>
Do not wet	<input type="checkbox"/>
Do not clean with high pressure cleaner (outdoor products)	<input type="checkbox"/>

Specific information	
Check extra information attached on the product	<input type="checkbox"/>

Materials												
Solid wood oiled	Waxed wood	Varnished or stained wood	Wood panel covered with decorative paper	Metamine covered panels	Lacquered surface	Stones	Leather	Metal	Plastic	Textile	Enducted textile (PU, PVC)	Product with electrical parts
<input type="checkbox"/>	<input type="checkbox"/>	<input type="checkbox"/>	<input type="checkbox"/>	<input type="checkbox"/>	<input type="checkbox"/>	<input type="checkbox"/>	<input type="checkbox"/>	<input type="checkbox"/>	<input type="checkbox"/>	<input type="checkbox"/>	<input type="checkbox"/>	<input type="checkbox"/>
<input type="checkbox"/>	<input type="checkbox"/>	<input type="checkbox"/>	<input type="checkbox"/>	<input type="checkbox"/>	<input type="checkbox"/>	<input type="checkbox"/>	<input type="checkbox"/>	<input type="checkbox"/>	<input type="checkbox"/>	<input type="checkbox"/>	<input type="checkbox"/>	<input type="checkbox"/>
<input type="checkbox"/>	<input type="checkbox"/>	<input type="checkbox"/>	<input type="checkbox"/>	<input type="checkbox"/>	<input type="checkbox"/>	<input type="checkbox"/>	<input type="checkbox"/>	<input type="checkbox"/>	<input type="checkbox"/>	<input type="checkbox"/>	<input type="checkbox"/>	<input type="checkbox"/>
<input type="checkbox"/>	<input type="checkbox"/>	<input type="checkbox"/>	<input type="checkbox"/>	<input type="checkbox"/>	<input type="checkbox"/>	<input type="checkbox"/>	<input type="checkbox"/>	<input type="checkbox"/>	<input type="checkbox"/>	<input type="checkbox"/>	<input type="checkbox"/>	<input type="checkbox"/>
<input type="checkbox"/>	<input type="checkbox"/>	<input type="checkbox"/>	<input type="checkbox"/>	<input type="checkbox"/>	<input type="checkbox"/>	<input type="checkbox"/>	<input type="checkbox"/>	<input type="checkbox"/>	<input type="checkbox"/>	<input type="checkbox"/>	<input type="checkbox"/>	<input type="checkbox"/>

<input type="checkbox"/>	<input type="checkbox"/>	<input type="checkbox"/>	<input type="checkbox"/>	<input type="checkbox"/>	<input type="checkbox"/>	<input type="checkbox"/>	<input type="checkbox"/>	<input type="checkbox"/>	<input type="checkbox"/>	<input type="checkbox"/>	<input type="checkbox"/>	<input type="checkbox"/>
<input type="checkbox"/>	<input type="checkbox"/>	<input type="checkbox"/>	<input type="checkbox"/>	<input type="checkbox"/>	<input type="checkbox"/>	<input type="checkbox"/>	<input type="checkbox"/>	<input type="checkbox"/>	<input type="checkbox"/>	<input type="checkbox"/>	<input type="checkbox"/>	<input type="checkbox"/>
<input type="checkbox"/>	<input type="checkbox"/>	<input type="checkbox"/>	<input type="checkbox"/>	<input type="checkbox"/>	<input type="checkbox"/>	<input type="checkbox"/>	<input type="checkbox"/>	<input type="checkbox"/>	<input type="checkbox"/>	<input type="checkbox"/>	<input type="checkbox"/>	<input type="checkbox"/>
<input type="checkbox"/>	<input type="checkbox"/>	<input type="checkbox"/>	<input type="checkbox"/>	<input type="checkbox"/>	<input type="checkbox"/>	<input type="checkbox"/>	<input type="checkbox"/>	<input type="checkbox"/>	<input type="checkbox"/>	<input type="checkbox"/>	<input type="checkbox"/>	<input type="checkbox"/>
<input type="checkbox"/>	<input type="checkbox"/>	<input type="checkbox"/>	<input type="checkbox"/>	<input type="checkbox"/>	<input type="checkbox"/>	<input type="checkbox"/>	<input type="checkbox"/>	<input type="checkbox"/>	<input type="checkbox"/>	<input type="checkbox"/>	<input type="checkbox"/>	<input type="checkbox"/>
<input type="checkbox"/>	<input type="checkbox"/>	<input type="checkbox"/>	<input type="checkbox"/>	<input type="checkbox"/>	<input type="checkbox"/>	<input type="checkbox"/>	<input type="checkbox"/>	<input type="checkbox"/>	<input type="checkbox"/>	<input type="checkbox"/>	<input type="checkbox"/>	<input type="checkbox"/>

<input type="checkbox"/>	<input type="checkbox"/>	<input type="checkbox"/>	<input type="checkbox"/>	<input type="checkbox"/>	<input type="checkbox"/>	<input type="checkbox"/>	<input type="checkbox"/>	<input type="checkbox"/>	<input type="checkbox"/>	<input type="checkbox"/>	<input type="checkbox"/>	<input type="checkbox"/>
--------------------------	--------------------------	--------------------------	--------------------------	--------------------------	--------------------------	--------------------------	--------------------------	--------------------------	--------------------------	--------------------------	--------------------------	--------------------------



Conseils d'entretien et de nettoyage

- Ne forcez jamais les connexions.
- Conservez le manuel de montage ; en cas de pièce manquante, c'est le moyen le plus simple de contacter le magasin.
- N'utilisez pas de poudres abrasives, laine d'acier ou solvants.
- Ne mouillez pas le produit.
- Enlevez délicatement la poussière.
- Utilisez un chiffon légèrement humide.

Instructions d'entretien

Chiffon doux légèrement humide
Eau savonneuse
Eau avec détergent
Éponge non abrasive
Entretien spécifique du fabricant

⚠ Avertissements ⚠

Avant tout entretien, enlever la poussière avec soin
Toute tache doit être nettoyée rapidement
N'utilisez jamais de produit abrasif (poudre, laine d'acier)
N'utilisez jamais de solvant
Ne pas mouiller
Ne pas nettoyer avec un nettoyeur haute pression (produits extérieurs)

Informations spécifiques

Consultez les informations supplémentaires jointes au produit.
--

Matériaux

Bois massif huilé	Bois ciré	Bois verni ou teinté	Panneau bois avec papier décoratif	Panneaux revêtus de mélamine	Surface laquée	Pierres	Cuir	Métal	Plastique	Tissu	Tissu enduit (PU, PVC)	Produit avec éléments électriques
-------------------	-----------	----------------------	------------------------------------	------------------------------	----------------	---------	------	-------	-----------	-------	------------------------	-----------------------------------

<input type="checkbox"/>	<input type="checkbox"/>	<input type="checkbox"/>	<input type="checkbox"/>	<input type="checkbox"/>	<input type="checkbox"/>	<input type="checkbox"/>	<input type="checkbox"/>	<input type="checkbox"/>	<input type="checkbox"/>	<input type="checkbox"/>	<input type="checkbox"/>	<input type="checkbox"/>
<input type="checkbox"/>	<input type="checkbox"/>	<input type="checkbox"/>	<input type="checkbox"/>	<input type="checkbox"/>	<input type="checkbox"/>	<input type="checkbox"/>	<input type="checkbox"/>	<input type="checkbox"/>	<input type="checkbox"/>	<input type="checkbox"/>	<input type="checkbox"/>	<input type="checkbox"/>
<input type="checkbox"/>	<input type="checkbox"/>	<input type="checkbox"/>	<input type="checkbox"/>	<input type="checkbox"/>	<input type="checkbox"/>	<input type="checkbox"/>	<input type="checkbox"/>	<input type="checkbox"/>	<input type="checkbox"/>	<input type="checkbox"/>	<input type="checkbox"/>	<input type="checkbox"/>
<input type="checkbox"/>	<input type="checkbox"/>	<input type="checkbox"/>	<input type="checkbox"/>	<input type="checkbox"/>	<input type="checkbox"/>	<input type="checkbox"/>	<input type="checkbox"/>	<input type="checkbox"/>	<input type="checkbox"/>	<input type="checkbox"/>	<input type="checkbox"/>	<input type="checkbox"/>
<input type="checkbox"/>	<input type="checkbox"/>	<input type="checkbox"/>	<input type="checkbox"/>	<input type="checkbox"/>	<input type="checkbox"/>	<input type="checkbox"/>	<input type="checkbox"/>	<input type="checkbox"/>	<input type="checkbox"/>	<input type="checkbox"/>	<input type="checkbox"/>	<input type="checkbox"/>

<input type="checkbox"/>	<input type="checkbox"/>	<input type="checkbox"/>	<input type="checkbox"/>	<input type="checkbox"/>	<input type="checkbox"/>	<input type="checkbox"/>	<input type="checkbox"/>	<input type="checkbox"/>	<input type="checkbox"/>	<input type="checkbox"/>	<input type="checkbox"/>	<input type="checkbox"/>
<input type="checkbox"/>	<input type="checkbox"/>	<input type="checkbox"/>	<input type="checkbox"/>	<input type="checkbox"/>	<input type="checkbox"/>	<input type="checkbox"/>	<input type="checkbox"/>	<input type="checkbox"/>	<input type="checkbox"/>	<input type="checkbox"/>	<input type="checkbox"/>	<input type="checkbox"/>
<input type="checkbox"/>	<input type="checkbox"/>	<input type="checkbox"/>	<input type="checkbox"/>	<input type="checkbox"/>	<input type="checkbox"/>	<input type="checkbox"/>	<input type="checkbox"/>	<input type="checkbox"/>	<input type="checkbox"/>	<input type="checkbox"/>	<input type="checkbox"/>	<input type="checkbox"/>
<input type="checkbox"/>	<input type="checkbox"/>	<input type="checkbox"/>	<input type="checkbox"/>	<input type="checkbox"/>	<input type="checkbox"/>	<input type="checkbox"/>	<input type="checkbox"/>	<input type="checkbox"/>	<input type="checkbox"/>	<input type="checkbox"/>	<input type="checkbox"/>	<input type="checkbox"/>
<input type="checkbox"/>	<input type="checkbox"/>	<input type="checkbox"/>	<input type="checkbox"/>	<input type="checkbox"/>	<input type="checkbox"/>	<input type="checkbox"/>	<input type="checkbox"/>	<input type="checkbox"/>	<input type="checkbox"/>	<input type="checkbox"/>	<input type="checkbox"/>	<input type="checkbox"/>
<input type="checkbox"/>	<input type="checkbox"/>	<input type="checkbox"/>	<input type="checkbox"/>	<input type="checkbox"/>	<input type="checkbox"/>	<input type="checkbox"/>	<input type="checkbox"/>	<input type="checkbox"/>	<input type="checkbox"/>	<input type="checkbox"/>	<input type="checkbox"/>	<input type="checkbox"/>

<input type="checkbox"/>	<input type="checkbox"/>	<input type="checkbox"/>	<input type="checkbox"/>	<input type="checkbox"/>	<input type="checkbox"/>	<input type="checkbox"/>	<input type="checkbox"/>	<input type="checkbox"/>	<input type="checkbox"/>	<input type="checkbox"/>	<input type="checkbox"/>	<input type="checkbox"/>
--------------------------	--------------------------	--------------------------	--------------------------	--------------------------	--------------------------	--------------------------	--------------------------	--------------------------	--------------------------	--------------------------	--------------------------	--------------------------



Consigli per la manutenzione e la pulizia

- Non forzare mai i collegamenti.
- Conservare il manuale di montaggio; se manca un pezzo, è il modo più semplice per contattare il negozio.
- Non utilizzare polveri abrasive, lana d'acciaio o solventi.
- Non bagnare il prodotto.
- Rimuovere delicatamente la polvere.
- Usare un panno leggermente umido.

Istruzioni per la manutenzione	
Panno morbido leggermente umido	<input type="checkbox"/>
Acqua saponata	<input type="checkbox"/>
Acqua con detergente	<input type="checkbox"/>
Spugna antigraffio	<input type="checkbox"/>
Manutenzione specifica del produttore	<input type="checkbox"/>

⚠ Avvertenze ⚠	
Prima di ogni manutenzione, rimuovere la polvere con cura	<input type="checkbox"/>
Qualsiasi macchia deve essere pulita subito	<input type="checkbox"/>
Non usare mai prodotti abrasivi (polvere, lana d'acciaio)	<input type="checkbox"/>
Non usare solventi	<input type="checkbox"/>
Non bagnare	<input type="checkbox"/>
Non pulire con idropulitrice (prodotti da esterno)	<input type="checkbox"/>

Informazioni specifiche	
Consultare le informazioni aggiuntive allegate al prodotto.	<input type="checkbox"/>

Materiali													
Legno massiccio oliato	<input type="checkbox"/>	<input type="checkbox"/>	<input type="checkbox"/>	<input type="checkbox"/>	<input type="checkbox"/>	<input type="checkbox"/>	<input type="checkbox"/>	<input type="checkbox"/>	<input type="checkbox"/>	<input type="checkbox"/>	<input type="checkbox"/>	<input type="checkbox"/>	<input type="checkbox"/>
Legno cerato	<input type="checkbox"/>	<input type="checkbox"/>	<input type="checkbox"/>	<input type="checkbox"/>	<input type="checkbox"/>	<input type="checkbox"/>	<input type="checkbox"/>	<input type="checkbox"/>	<input type="checkbox"/>	<input type="checkbox"/>	<input type="checkbox"/>	<input type="checkbox"/>	<input type="checkbox"/>
Legno verniciato o tinto	<input type="checkbox"/>	<input type="checkbox"/>	<input type="checkbox"/>	<input type="checkbox"/>	<input type="checkbox"/>	<input type="checkbox"/>	<input type="checkbox"/>	<input type="checkbox"/>	<input type="checkbox"/>	<input type="checkbox"/>	<input type="checkbox"/>	<input type="checkbox"/>	<input type="checkbox"/>
Pannello in legno con carta decorativa	<input type="checkbox"/>	<input type="checkbox"/>	<input type="checkbox"/>	<input type="checkbox"/>	<input type="checkbox"/>	<input type="checkbox"/>	<input type="checkbox"/>	<input type="checkbox"/>	<input type="checkbox"/>	<input type="checkbox"/>	<input type="checkbox"/>	<input type="checkbox"/>	<input type="checkbox"/>
Pannelli rivestiti in melamina	<input type="checkbox"/>	<input type="checkbox"/>	<input type="checkbox"/>	<input type="checkbox"/>	<input type="checkbox"/>	<input type="checkbox"/>	<input type="checkbox"/>	<input type="checkbox"/>	<input type="checkbox"/>	<input type="checkbox"/>	<input type="checkbox"/>	<input type="checkbox"/>	<input type="checkbox"/>
Superficie laccata	<input type="checkbox"/>	<input type="checkbox"/>	<input type="checkbox"/>	<input type="checkbox"/>	<input type="checkbox"/>	<input type="checkbox"/>	<input type="checkbox"/>	<input type="checkbox"/>	<input type="checkbox"/>	<input type="checkbox"/>	<input type="checkbox"/>	<input type="checkbox"/>	<input type="checkbox"/>
Pietre	<input type="checkbox"/>	<input type="checkbox"/>	<input type="checkbox"/>	<input type="checkbox"/>	<input type="checkbox"/>	<input type="checkbox"/>	<input type="checkbox"/>	<input type="checkbox"/>	<input type="checkbox"/>	<input type="checkbox"/>	<input type="checkbox"/>	<input type="checkbox"/>	<input type="checkbox"/>
Pelle	<input type="checkbox"/>	<input type="checkbox"/>	<input type="checkbox"/>	<input type="checkbox"/>	<input type="checkbox"/>	<input type="checkbox"/>	<input type="checkbox"/>	<input type="checkbox"/>	<input type="checkbox"/>	<input type="checkbox"/>	<input type="checkbox"/>	<input type="checkbox"/>	<input type="checkbox"/>
Metallo	<input type="checkbox"/>	<input type="checkbox"/>	<input type="checkbox"/>	<input type="checkbox"/>	<input type="checkbox"/>	<input type="checkbox"/>	<input type="checkbox"/>	<input type="checkbox"/>	<input type="checkbox"/>	<input type="checkbox"/>	<input type="checkbox"/>	<input type="checkbox"/>	<input type="checkbox"/>
Plastica	<input type="checkbox"/>	<input type="checkbox"/>	<input type="checkbox"/>	<input type="checkbox"/>	<input type="checkbox"/>	<input type="checkbox"/>	<input type="checkbox"/>	<input type="checkbox"/>	<input type="checkbox"/>	<input type="checkbox"/>	<input type="checkbox"/>	<input type="checkbox"/>	<input type="checkbox"/>
Tessuto	<input type="checkbox"/>	<input type="checkbox"/>	<input type="checkbox"/>	<input type="checkbox"/>	<input type="checkbox"/>	<input type="checkbox"/>	<input type="checkbox"/>	<input type="checkbox"/>	<input type="checkbox"/>	<input type="checkbox"/>	<input type="checkbox"/>	<input type="checkbox"/>	<input type="checkbox"/>
Tessuto spalmato (PU, PVC)	<input type="checkbox"/>	<input type="checkbox"/>	<input type="checkbox"/>	<input type="checkbox"/>	<input type="checkbox"/>	<input type="checkbox"/>	<input type="checkbox"/>	<input type="checkbox"/>	<input type="checkbox"/>	<input type="checkbox"/>	<input type="checkbox"/>	<input type="checkbox"/>	<input type="checkbox"/>
Prodotto con parti elettriche	<input type="checkbox"/>	<input type="checkbox"/>	<input type="checkbox"/>	<input type="checkbox"/>	<input type="checkbox"/>	<input type="checkbox"/>	<input type="checkbox"/>	<input type="checkbox"/>	<input type="checkbox"/>	<input type="checkbox"/>	<input type="checkbox"/>	<input type="checkbox"/>	<input type="checkbox"/>

<input type="checkbox"/>	<input type="checkbox"/>	<input type="checkbox"/>	<input type="checkbox"/>	<input type="checkbox"/>	<input type="checkbox"/>	<input type="checkbox"/>	<input type="checkbox"/>	<input type="checkbox"/>	<input type="checkbox"/>	<input type="checkbox"/>	<input type="checkbox"/>	<input type="checkbox"/>	<input type="checkbox"/>
<input type="checkbox"/>	<input type="checkbox"/>	<input type="checkbox"/>	<input type="checkbox"/>	<input type="checkbox"/>	<input type="checkbox"/>	<input type="checkbox"/>	<input type="checkbox"/>	<input type="checkbox"/>	<input type="checkbox"/>	<input type="checkbox"/>	<input type="checkbox"/>	<input type="checkbox"/>	<input type="checkbox"/>
<input type="checkbox"/>	<input type="checkbox"/>	<input type="checkbox"/>	<input type="checkbox"/>	<input type="checkbox"/>	<input type="checkbox"/>	<input type="checkbox"/>	<input type="checkbox"/>	<input type="checkbox"/>	<input type="checkbox"/>	<input type="checkbox"/>	<input type="checkbox"/>	<input type="checkbox"/>	<input type="checkbox"/>
<input type="checkbox"/>	<input type="checkbox"/>	<input type="checkbox"/>	<input type="checkbox"/>	<input type="checkbox"/>	<input type="checkbox"/>	<input type="checkbox"/>	<input type="checkbox"/>	<input type="checkbox"/>	<input type="checkbox"/>	<input type="checkbox"/>	<input type="checkbox"/>	<input type="checkbox"/>	<input type="checkbox"/>
<input type="checkbox"/>	<input type="checkbox"/>	<input type="checkbox"/>	<input type="checkbox"/>	<input type="checkbox"/>	<input type="checkbox"/>	<input type="checkbox"/>	<input type="checkbox"/>	<input type="checkbox"/>	<input type="checkbox"/>	<input type="checkbox"/>	<input type="checkbox"/>	<input type="checkbox"/>	<input type="checkbox"/>

<input type="checkbox"/>	<input type="checkbox"/>	<input type="checkbox"/>	<input type="checkbox"/>	<input type="checkbox"/>	<input type="checkbox"/>	<input type="checkbox"/>	<input type="checkbox"/>	<input type="checkbox"/>	<input type="checkbox"/>	<input type="checkbox"/>	<input type="checkbox"/>	<input type="checkbox"/>	<input type="checkbox"/>
<input type="checkbox"/>	<input type="checkbox"/>	<input type="checkbox"/>	<input type="checkbox"/>	<input type="checkbox"/>	<input type="checkbox"/>	<input type="checkbox"/>	<input type="checkbox"/>	<input type="checkbox"/>	<input type="checkbox"/>	<input type="checkbox"/>	<input type="checkbox"/>	<input type="checkbox"/>	<input type="checkbox"/>
<input type="checkbox"/>	<input type="checkbox"/>	<input type="checkbox"/>	<input type="checkbox"/>	<input type="checkbox"/>	<input type="checkbox"/>	<input type="checkbox"/>	<input type="checkbox"/>	<input type="checkbox"/>	<input type="checkbox"/>	<input type="checkbox"/>	<input type="checkbox"/>	<input type="checkbox"/>	<input type="checkbox"/>
<input type="checkbox"/>	<input type="checkbox"/>	<input type="checkbox"/>	<input type="checkbox"/>	<input type="checkbox"/>	<input type="checkbox"/>	<input type="checkbox"/>	<input type="checkbox"/>	<input type="checkbox"/>	<input type="checkbox"/>	<input type="checkbox"/>	<input type="checkbox"/>	<input type="checkbox"/>	<input type="checkbox"/>
<input type="checkbox"/>	<input type="checkbox"/>	<input type="checkbox"/>	<input type="checkbox"/>	<input type="checkbox"/>	<input type="checkbox"/>	<input type="checkbox"/>	<input type="checkbox"/>	<input type="checkbox"/>	<input type="checkbox"/>	<input type="checkbox"/>	<input type="checkbox"/>	<input type="checkbox"/>	<input type="checkbox"/>

<input type="checkbox"/>	<input type="checkbox"/>	<input type="checkbox"/>	<input type="checkbox"/>	<input type="checkbox"/>	<input type="checkbox"/>	<input type="checkbox"/>	<input type="checkbox"/>	<input type="checkbox"/>	<input type="checkbox"/>	<input type="checkbox"/>	<input type="checkbox"/>	<input type="checkbox"/>	<input type="checkbox"/>
--------------------------	--------------------------	--------------------------	--------------------------	--------------------------	--------------------------	--------------------------	--------------------------	--------------------------	--------------------------	--------------------------	--------------------------	--------------------------	--------------------------



Conselhos de manutenção e limpeza

- Nunca force as ligações.
- Guarde o manual de montagem; se faltar alguma peça, é a forma mais fácil de contactar a loja.
- Não use pós abrasivos, palha de aço ou solventes.
- Não molhe o produto.
- Remova cuidadosamente o pó.
- Use um pano ligeiramente húmido.

Instruções de manutenção

Pano macio ligeiramente húmido
Água com sabão
Água com detergente
Esponja anti-riscos
Manutenção específica do fabricante

⚠ Advertências ⚠

Antes de qualquer manutenção, limpe cuidadosamente o pó
Qualquer mancha deve ser limpa rapidamente
Nunca use produtos abrasivos (pó, palha de aço)
Nunca use solventes
Não molhar
Não limpar com lavadora de alta pressão (produtos de exterior)

Informações específicas

Consulte as informações adicionais anexadas ao produto.

Materiais

Madeira maciça com óleo	Madeira encerada	Madeira envernizada ou tingida	Painel de madeira com papel decorativo	Painéis revestidos com melamina	Superfície lacada	Pedras	Couro	Metal	Plástico	Têxtil	Tecido revestido (PU, PVC)	Produto com partes elétricas
-------------------------	------------------	--------------------------------	--	---------------------------------	-------------------	--------	-------	-------	----------	--------	----------------------------	------------------------------

<input type="checkbox"/>	<input type="checkbox"/>	<input type="checkbox"/>	<input type="checkbox"/>	<input type="checkbox"/>	<input type="checkbox"/>	<input type="checkbox"/>	<input type="checkbox"/>	<input type="checkbox"/>	<input type="checkbox"/>	<input type="checkbox"/>	<input type="checkbox"/>	<input type="checkbox"/>
<input type="checkbox"/>	<input type="checkbox"/>	<input type="checkbox"/>	<input type="checkbox"/>	<input type="checkbox"/>	<input type="checkbox"/>	<input type="checkbox"/>	<input type="checkbox"/>	<input type="checkbox"/>	<input type="checkbox"/>	<input type="checkbox"/>	<input type="checkbox"/>	<input type="checkbox"/>
<input type="checkbox"/>	<input type="checkbox"/>	<input type="checkbox"/>	<input type="checkbox"/>	<input type="checkbox"/>	<input type="checkbox"/>	<input type="checkbox"/>	<input type="checkbox"/>	<input type="checkbox"/>	<input type="checkbox"/>	<input type="checkbox"/>	<input type="checkbox"/>	<input type="checkbox"/>
<input type="checkbox"/>	<input type="checkbox"/>	<input type="checkbox"/>	<input type="checkbox"/>	<input type="checkbox"/>	<input type="checkbox"/>	<input type="checkbox"/>	<input type="checkbox"/>	<input type="checkbox"/>	<input type="checkbox"/>	<input type="checkbox"/>	<input type="checkbox"/>	<input type="checkbox"/>

<input type="checkbox"/>	<input type="checkbox"/>	<input type="checkbox"/>	<input type="checkbox"/>	<input type="checkbox"/>	<input type="checkbox"/>	<input type="checkbox"/>	<input type="checkbox"/>	<input type="checkbox"/>	<input type="checkbox"/>	<input type="checkbox"/>	<input type="checkbox"/>	<input type="checkbox"/>
<input type="checkbox"/>	<input type="checkbox"/>	<input type="checkbox"/>	<input type="checkbox"/>	<input type="checkbox"/>	<input type="checkbox"/>	<input type="checkbox"/>	<input type="checkbox"/>	<input type="checkbox"/>	<input type="checkbox"/>	<input type="checkbox"/>	<input type="checkbox"/>	<input type="checkbox"/>
<input type="checkbox"/>	<input type="checkbox"/>	<input type="checkbox"/>	<input type="checkbox"/>	<input type="checkbox"/>	<input type="checkbox"/>	<input type="checkbox"/>	<input type="checkbox"/>	<input type="checkbox"/>	<input type="checkbox"/>	<input type="checkbox"/>	<input type="checkbox"/>	<input type="checkbox"/>
<input type="checkbox"/>	<input type="checkbox"/>	<input type="checkbox"/>	<input type="checkbox"/>	<input type="checkbox"/>	<input type="checkbox"/>	<input type="checkbox"/>	<input type="checkbox"/>	<input type="checkbox"/>	<input type="checkbox"/>	<input type="checkbox"/>	<input type="checkbox"/>	<input type="checkbox"/>
<input type="checkbox"/>	<input type="checkbox"/>	<input type="checkbox"/>	<input type="checkbox"/>	<input type="checkbox"/>	<input type="checkbox"/>	<input type="checkbox"/>	<input type="checkbox"/>	<input type="checkbox"/>	<input type="checkbox"/>	<input type="checkbox"/>	<input type="checkbox"/>	<input type="checkbox"/>

<input type="checkbox"/>	<input type="checkbox"/>	<input type="checkbox"/>	<input type="checkbox"/>	<input type="checkbox"/>	<input type="checkbox"/>	<input type="checkbox"/>	<input type="checkbox"/>	<input type="checkbox"/>	<input type="checkbox"/>	<input type="checkbox"/>	<input type="checkbox"/>	<input type="checkbox"/>
--------------------------	--------------------------	--------------------------	--------------------------	--------------------------	--------------------------	--------------------------	--------------------------	--------------------------	--------------------------	--------------------------	--------------------------	--------------------------



Hinweise zur Pflege und Reinigung

- Erzwingen Sie keine Verbindungen.
- Bewahren Sie die Montageanleitung auf; fehlt ein Teil, ist dies der einfachste Weg, das Geschäft zu kontaktieren.
- Verwenden Sie keine Scheuermittel, Stahlwolle oder Lösungsmittel.
- Nicht nass machen.
- Staub vorsichtig entfernen.
- Ein leicht feuchtes Tuch verwenden.

Pflegehinweise	
Weiches, leicht feuchtes Tuch	<input type="checkbox"/>
Seifenwasser	<input type="checkbox"/>
Wasser mit Reinigungsmittel	<input type="checkbox"/>
Kratzfreie Scheuerschwamm	<input type="checkbox"/>
Herstellerspezifische Pflege	<input type="checkbox"/>

⚠ Warnhinweise ⚠	
Vor jeder Wartung Staub sorgfältig entfernen	<input type="checkbox"/>
Flecken sollten sofort entfernt werden	<input type="checkbox"/>
Keine scheuernden Produkte verwenden (Pulver, Stahlwolle)	<input type="checkbox"/>
Keine Lösungsmittel verwenden	<input type="checkbox"/>
Nicht nass machen	<input type="checkbox"/>
Nicht mit Hochdruckreiniger reinigen (für Außenprodukte)	<input type="checkbox"/>

Spezifische Informationen	
Beachten Sie die dem Produkt beiliegenden zusätzlichen Informationen.	<input type="checkbox"/>

Materialien													
Massivholz geölt	Gewachstes Holz	Lackiertes oder gebeiztes Holz	Holzplatte mit Dekorpapier	Melaminbeschichtete Platten	Lackierte Oberfläche	Steine	Leder	Metall	Kunststoff	Textil	Beschichteter Stoff (PU, PVC)	Produkt mit elektrischen Teilen	
<input type="checkbox"/>	<input type="checkbox"/>	<input type="checkbox"/>	<input type="checkbox"/>	<input type="checkbox"/>	<input type="checkbox"/>	<input type="checkbox"/>	<input type="checkbox"/>	<input type="checkbox"/>	<input type="checkbox"/>	<input type="checkbox"/>	<input type="checkbox"/>	<input type="checkbox"/>	
<input type="checkbox"/>	<input type="checkbox"/>	<input type="checkbox"/>	<input type="checkbox"/>	<input type="checkbox"/>	<input type="checkbox"/>	<input type="checkbox"/>	<input type="checkbox"/>	<input type="checkbox"/>	<input type="checkbox"/>	<input type="checkbox"/>	<input type="checkbox"/>	<input type="checkbox"/>	
<input type="checkbox"/>	<input type="checkbox"/>	<input type="checkbox"/>	<input type="checkbox"/>	<input type="checkbox"/>	<input type="checkbox"/>	<input type="checkbox"/>	<input type="checkbox"/>	<input type="checkbox"/>	<input type="checkbox"/>	<input type="checkbox"/>	<input type="checkbox"/>	<input type="checkbox"/>	
<input type="checkbox"/>	<input type="checkbox"/>	<input type="checkbox"/>	<input type="checkbox"/>	<input type="checkbox"/>	<input type="checkbox"/>	<input type="checkbox"/>	<input type="checkbox"/>	<input type="checkbox"/>	<input type="checkbox"/>	<input type="checkbox"/>	<input type="checkbox"/>	<input type="checkbox"/>	
<input type="checkbox"/>	<input type="checkbox"/>	<input type="checkbox"/>	<input type="checkbox"/>	<input type="checkbox"/>	<input type="checkbox"/>	<input type="checkbox"/>	<input type="checkbox"/>	<input type="checkbox"/>	<input type="checkbox"/>	<input type="checkbox"/>	<input type="checkbox"/>	<input type="checkbox"/>	

<input type="checkbox"/>	<input type="checkbox"/>	<input type="checkbox"/>	<input type="checkbox"/>	<input type="checkbox"/>	<input type="checkbox"/>	<input type="checkbox"/>	<input type="checkbox"/>	<input type="checkbox"/>	<input type="checkbox"/>	<input type="checkbox"/>	<input type="checkbox"/>	<input type="checkbox"/>
<input type="checkbox"/>	<input type="checkbox"/>	<input type="checkbox"/>	<input type="checkbox"/>	<input type="checkbox"/>	<input type="checkbox"/>	<input type="checkbox"/>	<input type="checkbox"/>	<input type="checkbox"/>	<input type="checkbox"/>	<input type="checkbox"/>	<input type="checkbox"/>	<input type="checkbox"/>
<input type="checkbox"/>	<input type="checkbox"/>	<input type="checkbox"/>	<input type="checkbox"/>	<input type="checkbox"/>	<input type="checkbox"/>	<input type="checkbox"/>	<input type="checkbox"/>	<input type="checkbox"/>	<input type="checkbox"/>	<input type="checkbox"/>	<input type="checkbox"/>	<input type="checkbox"/>
<input type="checkbox"/>	<input type="checkbox"/>	<input type="checkbox"/>	<input type="checkbox"/>	<input type="checkbox"/>	<input type="checkbox"/>	<input type="checkbox"/>	<input type="checkbox"/>	<input type="checkbox"/>	<input type="checkbox"/>	<input type="checkbox"/>	<input type="checkbox"/>	<input type="checkbox"/>
<input type="checkbox"/>	<input type="checkbox"/>	<input type="checkbox"/>	<input type="checkbox"/>	<input type="checkbox"/>	<input type="checkbox"/>	<input type="checkbox"/>	<input type="checkbox"/>	<input type="checkbox"/>	<input type="checkbox"/>	<input type="checkbox"/>	<input type="checkbox"/>	<input type="checkbox"/>
<input type="checkbox"/>	<input type="checkbox"/>	<input type="checkbox"/>	<input type="checkbox"/>	<input type="checkbox"/>	<input type="checkbox"/>	<input type="checkbox"/>	<input type="checkbox"/>	<input type="checkbox"/>	<input type="checkbox"/>	<input type="checkbox"/>	<input type="checkbox"/>	<input type="checkbox"/>

<input type="checkbox"/>	<input type="checkbox"/>	<input type="checkbox"/>	<input type="checkbox"/>	<input type="checkbox"/>	<input type="checkbox"/>	<input type="checkbox"/>	<input type="checkbox"/>	<input type="checkbox"/>	<input type="checkbox"/>	<input type="checkbox"/>	<input type="checkbox"/>	<input type="checkbox"/>
--------------------------	--------------------------	--------------------------	--------------------------	--------------------------	--------------------------	--------------------------	--------------------------	--------------------------	--------------------------	--------------------------	--------------------------	--------------------------



ES: IMPORTANTE: RECICLAJE.

Una vez finalizado el montaje:

- Deposita la caja de cartón en el contenedor de papel y cartón.
- Deposita las piezas plásticas no reutilizables en el contenedor de plásticos y envases.
- Si no quiere conservar este folleto, deposítalo en el contenedor de papel y cartón.

FR: IMPORTANT : RECYCLAGE.

Une fois le montage terminé :

- Déposez la boîte en carton dans le conteneur pour papier et carton.
- Déposez les pièces en plastique non réutilisables dans le conteneur pour plastiques et emballages.
- Si vous ne souhaitez pas conserver ce livret, déposez-le dans le conteneur pour papier et carton.

PT: IMPORTANTE: RECICLAGEM.

Após concluir a montagem:

- Coloque a caixa de cartão no contentor de papel e cartão.
- Coloque as peças plásticas não reutilizáveis no contentor de plásticos e embalagens.
- Se não quiser guardar este folheto, coloque-o no contentor de papel e cartão.

EN: IMPORTANT: RECYCLING.

Once assembly is complete:

- Place the cardboard box in the paper and cardboard recycling container.
- Place non-reusable plastic parts in the plastic and packaging recycling container.
- If you don't want to keep this leaflet, place it in the paper and cardboard recycling container.

IT: IMPORTANTE: RICICLAGGIO.

Una volta completato il montaggio:

- Smaltisci la scatola di cartone nel contenitore per carta e cartone.
- Smaltisci le parti in plastica non riutilizzabili nel contenitore per plastica e imballaggi.
- Se non desideri conservare questo libretto, gettalo nel contenitore per carta e cartone.

DE: WICHTIG: RECYCLING.

Nach dem Zusammenbau:

- Entsorge den Karton im Papier- und Kartoncontainer.
- Nicht wiederverwendbare Kunststoffteile gehören in den Container für Kunststoffe und Verpackungen.
- Wenn du dieses Heft nicht aufbewahren möchtest, wirf es in den Papier- und Kartoncontainer.

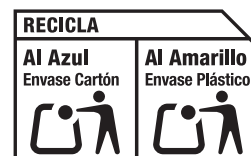

<https://quefairedemesdechets.fr>